

# Hallett

UV  
PURE

## Technicians Annual Service Guide.

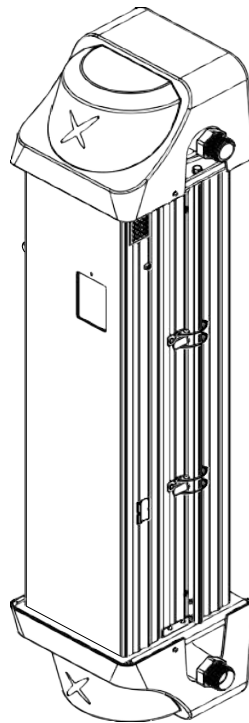

CROSS X FIRE TECHNOLOGY

 **WHITE**  
INTERNATIONAL

## Introduction: Annual service of Hallett UV

This service guide has been developed to assist technicians performing regular service work on Hallett UV units.

The guide recognises that the technician should have some general knowledge about the Hallett but that they are not performing this type of work frequently enough to be totally conversant with the more technical aspects.

In the event of something unexpected being discovered, information and guidance in greater detail is available.



**It is strongly recommended that the technician have a copy of the Hallett Instruction Manual to supplement this annual service guide**



[https://www.whiteint.co.nz/documents/Manuals/807756\\_500.pdf](https://www.whiteint.co.nz/documents/Manuals/807756_500.pdf)

## 5 yearly service – additional service tasks

After 5 years of operation, the following tasks are recommended:

- Replace the quartz sleeve including quartz seals.
- Clean the automatic quartz cleaning device (wiper assembly). Remove any build up of scale or minerals.

Technical document [GDQA – Quartz Sleeve replacement kit](#) explains the removal of the wiper assembly and replacement of the quartz sleeve in detail.

[Contact White International](#)

- Replace the seals within the top manifold for the wiper adapter.
- Replace the UV sensor

## General warnings

	<p>Read the manual carefully before starting</p>
	<p>Take care that power and water supply are isolated and that system pressure is relieved before undertaking service work beyond the scope of this guide.</p>
	<p>This appliance is not intended for use by persons (including children) with reduced physical, sensory or mental capabilities, or lack of experience and knowledge, unless they have been given supervision or instruction concerning use of the appliance by a person responsible for their safety. Children should be supervised to ensure that they do not play with the appliance.</p>
	<p>Ensure that the installation complies with all applicable local regulations.</p>

## Sequence – Annual Service

<b>Sequence – Annual Service</b> .....	3
<b>1. Review the main operational parameters</b> .....	3
<b>2. Reset the Lamp Life Counter</b> .....	3
<b>3. Review the System Info screens.</b> .....	4
<b>4. Isolate the power to the unit and allow the lamps to cool.</b> .....	4
<b>5. Check for dust and clean as required</b> .....	4
<b>6. Replace the filters.</b> .....	4
<b>7. Inspect inside of quartz sleeve for cleanliness</b> .....	5
<b>8. Replace both lamps</b> .....	5
<b>9. Restore power to the UV unit</b> .....	5
<b>10. Confirm the lamp lifetime counter is reset.</b> .....	5
<b>11. Recheck the main operational parameters.</b> .....	5
<b>12. Check operation of wiper, cooling fans and valves.</b> .....	6
<b>13. UV sensor reference check</b> .....	6
<b>14. Reflectance check (Hallett 1000 only): Optional</b> .....	7
<b>15. Trouble Shooting Guide</b> .....	8

### 1. Review the main operational parameters

Touch the display screen to wake it

From the main display screen, **record the current UV Dose, UVI and UVT values** on your annual service sheet (example supplied Appendix 1, Page 10)

### 2. Reset the Lamp Life Counter

See Appendix 2 for Menu structure (Page 11)



Press setting icon.

5<sup>th</sup> Button down – **Reset Lamp Counter**

365 days / 12 months for LPHO Lamps (Hallett 500 and 750 models)

500 days / 16.5 months for Amalgam Lamps (Hallett 1000)

### 3. Review the System Info screens.



Press the information button. Use the DOWN button  to scroll

Record the values on your annual service sheet (example supplied Appendix 2, Page XX)

1. Record the total lamp starts.
2. Total Starts
3. Power Ups
4. Lifetime counter
5. Check the unit message history.

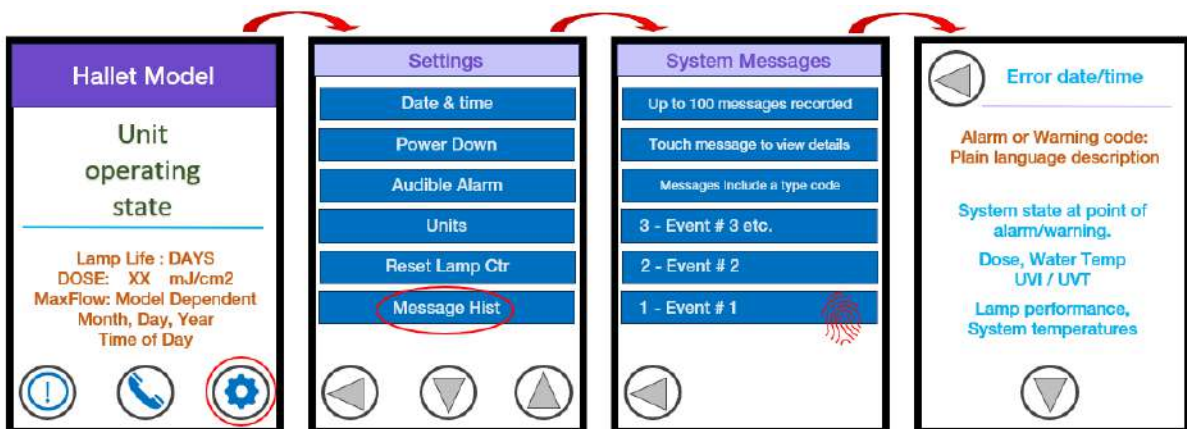

### 4. Isolate the power to the unit and allow the lamps to cool

### 5. Check for dust and clean as required

- Inspect the inside of the UV chamber for dust.
- Inspect the Printed Circuit Board(s) / ballast chamber for dust.

Remove all dust with a clean, soft cloth or soft brush.

- Inspect the surfaces of the reflectors. Note that the reflectors have a protective coating. Avoid the use of solvents i.e. rubbing alcohol

### 6. Replace the filters

Inspect the cleanliness of old air filter.

In dusty environments, filters may require changing more frequently.

Blocked filters hinder the internal cooling air-flow which may result in warnings/alarms

## 7. Inspect inside of quartz sleeve for cleanliness

If the quartz sleeve is dirty on the outside, proceed to wipe it down with a clean lint-free cloth and rubbing alcohol to remove the dirt.

If the quartz sleeve is dirty on the inside, proceed with in-place cleaning or disassembly.

In-place cleaning using a cleaning solution of citric acid, vinegar or other non-hazardous solutions is detailed in the Hallett instruction manual: Section 7 Maintenance

## 8. Replace both lamps

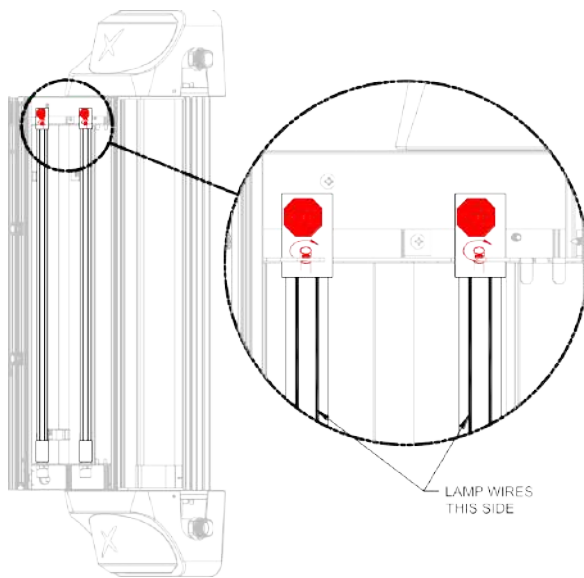

Install the lamps with the vertical wires facing toward you (away from the reflector)

When handling the lamps to avoid touching the glass with bare skin

Lamps can be cleaned using rubbing alcohol but care must be taken not to expose the reflector surface to any solvents

## 9. Restore power to the UV unit

The start-up cycle takes 15 min

If 'lamp-strike' errors occur repeatedly, remove the lamps and swop left to right

## 10. Confirm the lamp lifetime counter is reset

The display should show the correct Lamp Life value

- 365 days / 12 months for LPHO Lamps (Hallett 500 and 750 models)
- 500 days / 16.5 months for Amalgam Lamps (Hallett 1000)

## 11. Recheck the main operational parameters

Make a note of the UV Dose, UVI and UVT values

LPHO lamps (Hallett 500 and 750 models) require an initial 3 – 4 hr 'burn-in' period and may not achieve their full output for 24hrs. **After 15 minutes operation, the UVI value for the new lamps should be equal to or greater than the aged lamps.**



## 12. Check operation of wiper, cooling fans and valves

Use the force-output function in the  Settings / Advanced Settings menu

Purge valve

Shut off Valve

Wiper

PCB Cooling fan

UV Cooling Fan

## 13. UV sensor reference check

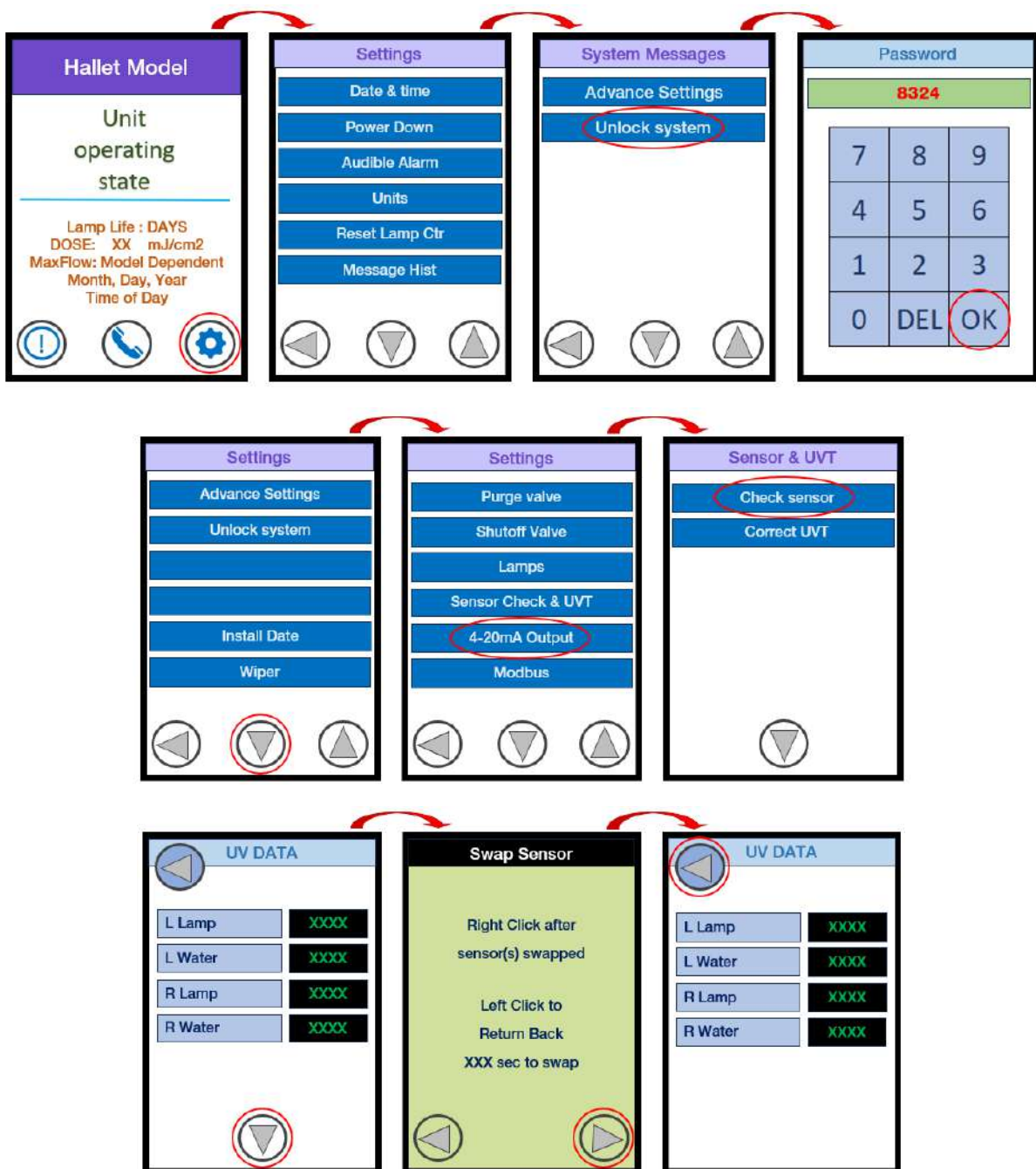

With the sensor removed, UV light from the lamps is visible. Exercise caution. Do not look inside the chamber

## 14. Reflectance check (Hallett 1000 only): Optional

The reflectance test, applicable only to H1000 models, should be carried out when strict adherence to the DVGM standard is required.

[Contact White International prior to undertaking these checks](#)

The purpose of the reflectance check is to examine if the performance of the reflectors within the UV chamber has diminished. The check involves recording the four UV sensor values with both lamps on, then with the left lamp on, then with the right lamp on.

A value less than 0.92 will begin to negatively impact the UV dose calculated by the Hallett 1000 unit (decreases RED by 5%).

Technical document [GH100 – Reflectance Check Procedure](#) details how to collect the necessary information.

A spreadsheet provided by UV Pure (GH100.xlsx) will calculate the reflectance.

Technical document [GH102 – Applying Reflectance, RED \(Technicians only\)](#) explains how to apply any correction

## Disinfection Procedure

A significant advantage of the Hallett UV unit is that as the sensor(s) and lamps are in air, under normal circumstances, replacement does not require breaking into the water supply.

However, a robust disinfection procedure is necessary after in-place cleaning of the quartz sleeve, quartz sleeve replacement or wiper maintenance.

The Hallett instruction manual provides advice: Section 7 Maintenance.

Silver stabilised Hydrogen Peroxide disinfection products such as Bianco HydraShield are an excellent alternative to disinfect systems post maintenance





## 15. Trouble Shooting Guide

Hallett UV disinfection units are designed to operate unattended until a fault arises. The fault may be related to incoming water quality or an issue with the unit itself.

The Force Outputs function in the Advanced Settings menu provides the ability to manually turn devices on and off to confirm their operation. Devices return back to their automatic position after 10 minutes.

Cycling the power will reset the system software

### **ALARMING**

Whenever an **alarm** occurs, the solenoid valve (if fitted) will close to prevent untreated water from flowing.

The **LED turns red**; the audio alarm beeps continuously; the touchscreen will turn **RED** and display a message.

The RUN contact will open to indicate the unit is no longer treating.

To return the unit to normal operation the fault will need to be identified and rectified.

### **WARNINGS**

If a **warning** occurs, the solenoid valve remains open

The **LED flashes red**; the audio alarm will beep once; the screen turns **YELLOW** and displays a message

The warning contact will close to indicate the unit is still treating but in an abnormal state.

The warning should be addressed as soon as possible. If left unresolved the issue may result in an ALARM.

The Message History contains up to 100 messages/events with associated recorded data such as times, UVI, UVT, UV sensor values, and temperatures.

In the event of an alarm, in many cases, a physical inspection of the unit with the power off should be done to try to identify a cause. A slow water leak for instance, near the top of the unit could stain lamps or reflectors and may not be uncovered without a full system inspection.

### **DOSE ALARM**

Dose Alarms occur when there is insufficient UV dose to treat the maximum flow rate prescribed by the unit.

The Dose Alarm may be due to low UV intensity OR low UV Transmittance (UVT) OR a combination of both.

Review both values in the System Info Menu to determine which is causing the alarm and take corrective action.

It is good practice to submit a UVT sample to confirm system prediction.



System Status	Possible Cause	Corrective Action
No Power: LED off, Touchscreen off	Ground-fault circuit-interrupter (GFCI) tripped.	Check for water leaks. Reset GFCI.
	Fuse Blown.	Check for water leaks. Replace fuse
	Touchscreen pcb not connected to power pcb.	Ensure ribbon cable is connected at both ends
	Circuit Board is damaged.	Confirm if the main power board has illuminated LEDs. If yes, replace Touchscreen PCB (LCD).
UV Lamps not starting: occurs after 6 unsuccessful attempts	UV Chamber interlock not engaged.	Check that each latch is correctly positioned and secure UV chamber door.
	Number of lamp starts have exceeded specification.	Review Total Lamp starts in System Info Menu. Replace lamps but reduce future lamp cycles.
	UV lamp failure	Replace lamps
	UV Ballast Failure	Replace ballast
	Over temperature condition.	Either the system, PCB or water temperature has occurred. Allow to cool off and investigate cause by reviewing Message History.
UV Lamps on but UVI is low	Lamps are warming up after a power interruption.	Allow lamps up to 15 minutes to reach full power
	New LPHO lamps installed. 500 and 570 models	First time LPHO lamps are turned on it may take 3 to 4 hours to reach full power. After this initial "burn-in", warmup time will be a few minutes.
	The UV output of the lamps have diminished.	Lamps have exceeded their lifetime. Replace lamps.
		Number of lamp starts have exceeded specification. Replace lamps but reduce future lamp cycles.
	UV sensor requires recalibration/replacement.	Install reference sensor to confirm status of unit sensor.
	UV Lamps operating outside of recommended temperature conditions.	Check if UV blower is operating correctly.
For cold water applications, increase room temperature or install LPHO lamp heater kit.		
High Water Temperature Warning & Alarm	<b>Hallett 500 and 570</b> Warning issued when water temperature within the UV chamber exceeds 40°C.  <b>Hallett 1000</b> Alarm issued when water temperature within the UV chamber exceeds 122°50°C – UV Lamps are turned off	Ensure sufficient water pressure available to operate purge valve. (0.5 bar) Check for blockage in purged discharge tubing. Check for debris in purge valve.
High System Temperature Warning & Alarm	The system temperature has exceeded a safe operating level causing the UV lamps to be turned off.	Check if water flow has been turned off. Check if operating temperatures have exceeded specifications. Check if both system blowers are operating correctly.
Circuit Board Temperature High Alarm	The temperature within the electrical chamber has exceeded a safe operating level causing the UV lamps to be turned off.	Check if operating temperatures have exceeded specifications. Check if the pcb blower is operating.
Wiper Not Turning Warning	The system has failed to detect wiper motion during the routine wiper cycle.	Check wiper motor operation
		Check wiper position switch & cam.
		The UVT is too low for detection. The Wiper Position Switch option is recommended.

# Appendix #1: Annual Log sheet

Date		Location	
Model #		Operator Name	
Serial #		Unit Status	

UV Dose
UVI
UVT

Lamp Life Remaining		Max Flow		Real-time clock correct? Y / N
PCB Temp.	Sys Temp.	Water Temp.	Lamp Temp.	
Firmware Ver.	Total Starts	Power ups	Life-time Cnt	
Left Lamp	Left Water			

#	Task Description	Performed	Comments
1	Review/record operational parameters		
2	Review the Message History		
5	Inspect Air Filter		
6	Inspect Inside of UV Chamber		
7	Inspect Inside of Quartz Sleeve		
8	Inspect Reflectors		
9	Inspect the PCB Area for Dust		
10	Confirm PCB Fan Operating		
11	Confirm UV Fan Operating		
12	Confirm Shutoff Valve Opens & Closes		
13	Perform UV Sensor Ref. Check		

Notes:

## Appendix #2 – Menu structure

### 0: Home - displays in normal operation

- 0.1 Model name
- 0.2 Treatment Status
- 0.3 Lamp Life
- 0.4 UV Dose
- 0.5 Max Flow or Flow Signal (Optional)
- 0.6 Date & Time



### 0A: Contact Info

Text: Company, Phone, Installation date



### 1: System Info

- 1.1 UVT
- 1.2 UVI
- 1.3 Left Lamp UV
- 1.4 Left Water UV
- 1.5 Right Lamp UV (If available)
- 1.6 Right Water UV (If available)
- 1.7 PCB Temp
- 1.8 Sys Temp
- 1.9 Water Temp
- 1.10 Lamp Temp
- 1.11 Wiper Countdown
- 1.12 Daily Starts
- 1.13 Firmware Version
- 1.14 Total Starts
- 1.15 Power-ups
- 1.16 Life-time counter
- 1.17 CH1 - Analog Output
- 1.18 CH2 - Analog Output



### 2: Settings

- 2.1 Date & Time
- 2.2 Power Down
- 2.3 Audible Alarm
- 2.4 Units – Metric/Imperial
- 2.5 Reset Lamp Counter
- 2.6 Message History - Last 100 messages >>>>>>
- 2.7 **Advanced Settings (see next page)**
- 2.8 Password for Advanced Menus

- Message #
- UV Dose
- Water temp
- Estimated UVI
- Estimated UVT
- Left Lamp UV
- Left water
- Left Lamp UV
- Left water
- Lamp temp
- PCB Temp
- System Temp

## 2.7 Advanced Settings

### 2.7.1 Force Outputs

**All functions return to their automatic state after 10 min**

2.7.1.1	Lamps
2.7.1.2	Wiper
2.7.1.3	Purge Valve
2.7.1.4	Shutoff Valve
2.7.1.5	Fan UV
2.7.1.6	Fan PCB
2.7.1.7	Warning Contact
2.7.1.8	Run Contact
2.7.1.9	Buzzer
2.7.1.10	Heaters
2.7.1.11	C1-4-20mA signal
2.7.1.12	C2-4-20mA signal
2.7.1.13	Interlock for UV door
2.7.1.14	Wiper Positioner switch
2.7.1.15	Remote Start/Stop Signal
2.7.1.16	Fault 1
2.7.1.17	Fault 2
2.7.1.18	Lamp Temp
2.7.1.19	Water Temp
2.7.1.20	Analog In
2.7.1.21	System Temp
2.7.1.22	PCB Temp
2.7.1.23	DC Volts
2.7.1.24	L Lamp Sensor
2.7.1.25	L Water Sensor
2.7.1.26	R Lamp Sensor
2.7.1.27	R Water Sensor
2.7.1.28	CAL - L Lamp
2.7.1.29	CAL - L Water
2.7.1.30	CAL - R Lamp
2.7.1.31	CAL - R Water

### 2.7.2 Remote Start

### 2.7.3 Shutoff Valve

### 2.7.4 Set Defaults

### 2.7.5 Language

Password for Advanced Menus ( **Default PW 8324** )



**[www.whiteint.com.au](http://www.whiteint.com.au)**

**[www.whiteint.co.nz](http://www.whiteint.co.nz)**

**Please always refer to our website for further technical information & new product innovations**

**Disclaimer:** Every effort has been made to publish the correct information in this manual. No responsibility will be taken for errors, omissions or changes in product specifications.

© 2023 Copyright White International Pty Ltd

TM ® - WARNING: Please be aware that various brands & products depicted within this document are subject to trademark, patent or design registrations. Infringement of any intellectual property contained within this document without express written authority by the appropriate intellectual property holder may result in further legal action to be taken. For any queries regarding use of the contained information please feel free to contact White International Pty Ltd.